

TWO-POST LIFTS

SPOA3T/40

SPO40/54/65



SPOA3T

THE NEW SPOA3T 2-POST LIFTS OFFER MAXIMUM DRIVE-THROUGH CLEARANCE WITH MINIMUM EXTERNAL DIMENSIONS. THE ASYMMETRICAL DESIGN OF THE POSTS AND SUPPORTING ARMS ALSO PROVIDES A SPACIOUS PICK-UP AREA – THE LIFT CAN BE ENTERED FROM EITHER SIDE.

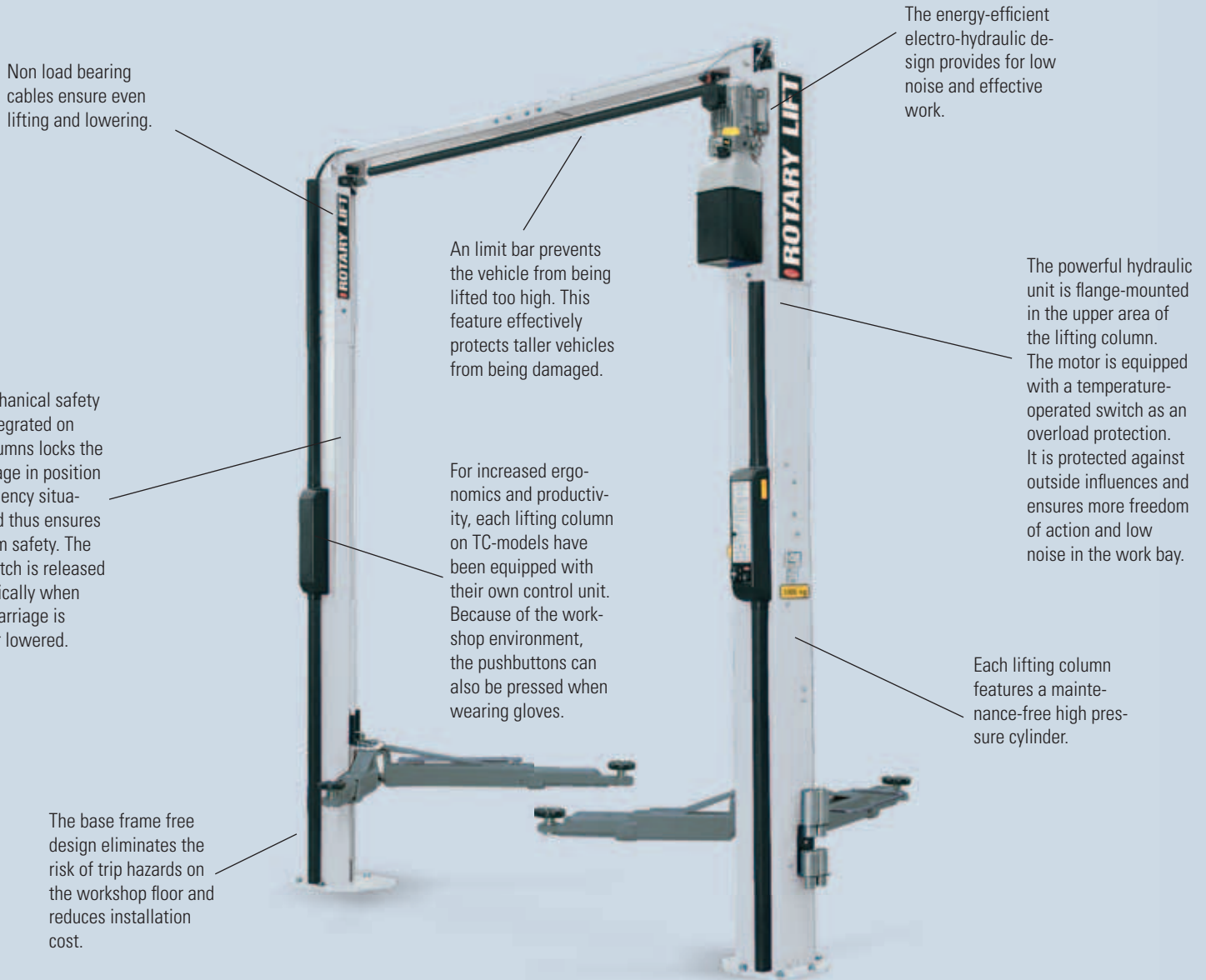

Non load bearing cables ensure even lifting and lowering.

The energy-efficient electro-hydraulic design provides for low noise and effective work.

An limit bar prevents the vehicle from being lifted too high. This feature effectively protects taller vehicles from being damaged.

The powerful hydraulic unit is flange-mounted in the upper area of the lifting column. The motor is equipped with a temperature-operated switch as an overload protection. It is protected against outside influences and ensures more freedom of action and low noise in the work bay.

The mechanical safety latch integrated on both columns locks the lift carriage in position in emergency situations and thus ensures maximum safety. The safety latch is released automatically when the lift carriage is raised or lowered.

For increased ergonomics and productivity, each lifting column on TC-models have been equipped with their own control unit. Because of the workshop environment, the pushbuttons can also be pressed when wearing gloves.

Each lifting column features a maintenance-free high pressure cylinder.

The base frame free design eliminates the risk of trip hazards on the workshop floor and reduces installation cost.

The figure shows SPOA3T with optional accessories.

DETAILS

The rear supporting arms can swivel through 180°. This substantially increases the pick-up flexibility, allowing vehicles with a short or long wheelbase to be lifted without difficulty.

The lift carriage bearings are made of self-lubricating and absolutely maintenance-free Tivar® 1000 polyethylene. Two characteristics that help reduce operating expenses considerably.

The supporting arms are automatically locked in position during the lifting operation. Once the lift has been completely lowered, this interlock is automatically released. The very narrow spacing between the locking positions and a manual unlocking function enhance the ease of use.

The modern, asymmetrical post design provides a generous drive-through clearance of 2,350 mm, so even large vehicles can be easily accommodated.

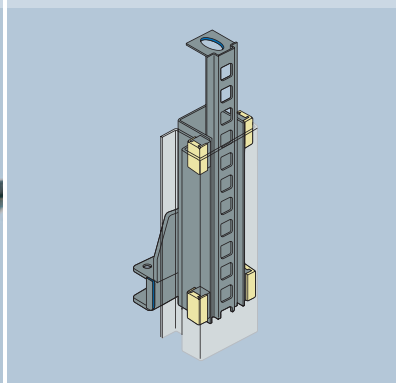

Model:	SPOA3TS	SPOA3TC
Capacity	3000 kg	3000 kg
A. Stroke	1959 mm	1959 mm
B. Overall height	3785 mm	3785 mm
EH1	3865 mm	3865 mm
EH2	4170 mm	4170 mm
C. Overall width	3000 mm	3000 mm
D. Drive through clearance	2336 mm	2336 mm
E. Switchoff level	3455 mm	3455 mm
EH1	3760 mm	3760 mm
EH2	4065 mm	4065 mm
F. Support bracket length on the front min.	536 mm	536 mm
G. Support bracket length on the front max.	1105 mm	1105 mm
H. Support bracket length on the rear min.	837 mm	837 mm
I. Support bracket length on the rear max.	1475 mm	1475 mm
J. Rotary plate height min.	89 mm	89 mm
K. Rotary plate height max.	159 mm	159 mm
M. Column spacing, interior dimension	2560 mm	2560 mm
N. Cylinder height at max. stroke*	3785 mm	3785 mm
Motor performance	4,0 kW	4,0 kW
Electrical connection (3 phases)	400 V, 50 Hz	400 V, 50 Hz
Lifting time	26 sec.	26 sec.
Required ceiling height	3800 mm	3800 mm
EH1	3920 mm	3920 mm
EH2	4230 mm	4230 mm

* Cylinder height with standard models larger than overall height.

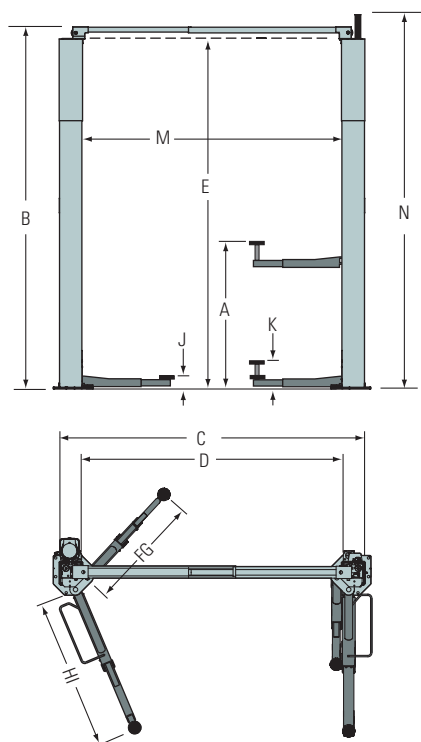

The asymmetrical construction combined with the design of the supporting arms provides good door clearance – either in front of or behind the lifting post.



ACCESSORIES

Support kit for delivery trucks/vans
(4 x U-support)

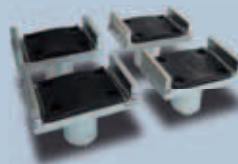

Sports car supporting arm
(3-stage)

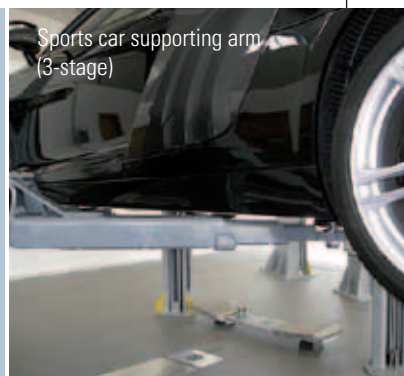

Rotary adaptor extension kit for
passenger cars
(4 x 89 mm, 4 x 127 mm)



Rotary adaptor extension kit for
delivery trucks/vans (4 x 200 mm)



Vehicle security for rotary plate
with 120 mm diameter



Tool storage trays, magnetic



SPOA40, SPO40

ELECTRO-HYDRAULIC TWO-POST LIFTS OF THE SPO SERIES CAN BE TAILORED PERFECTLY TO FIT THE APPLICATION. TWO DIFFERENT LOAD-BEARING CAPACITIES CAN BE COMBINED WITH UP TO FOUR DIFFERENT COLUMN HEIGHTS. THERE ARE ONE MANUAL AND ONE ELECTRICAL CONTROLLER VERSIONS TO CHOOSE FROM.

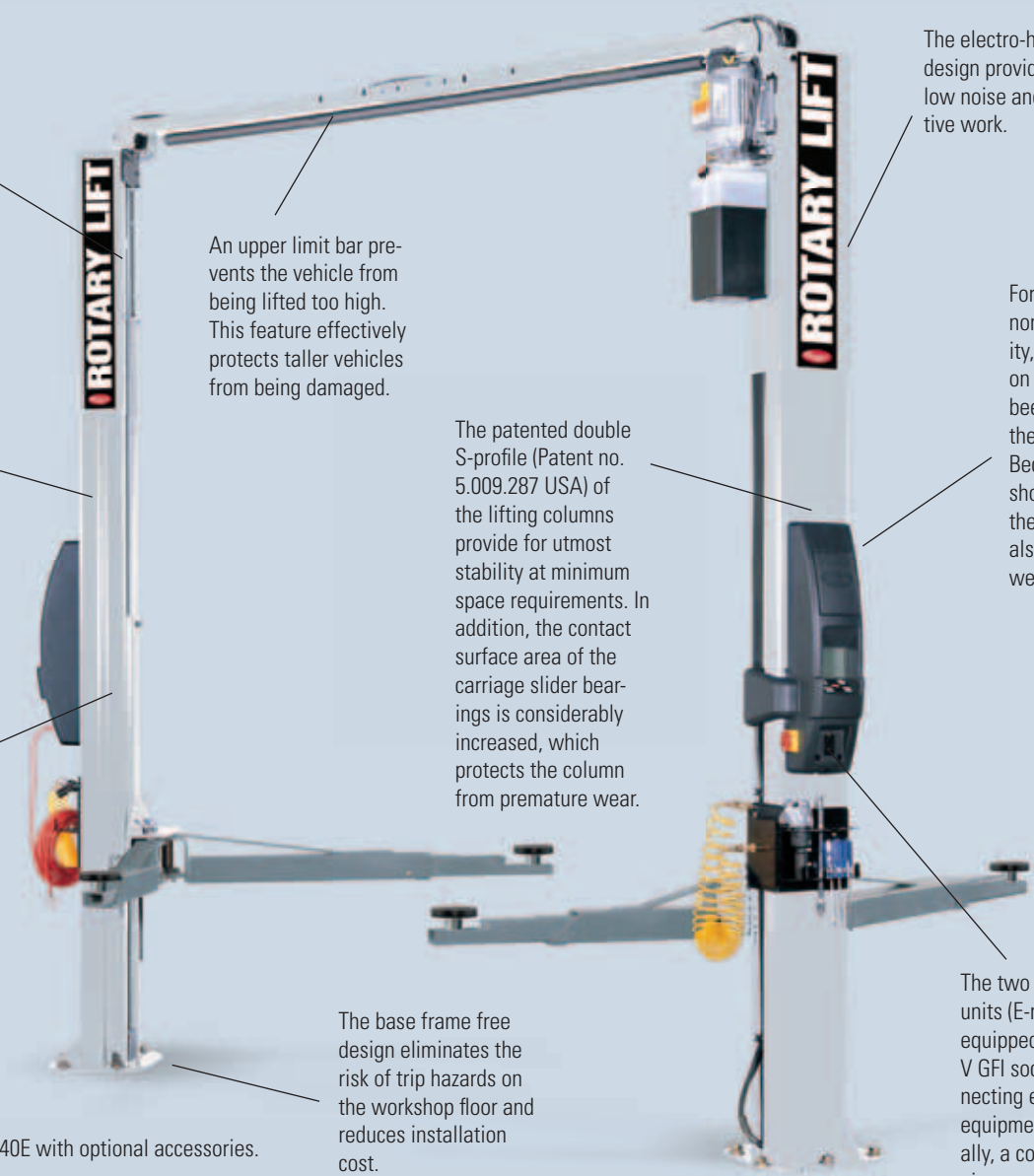

Non load bearing cables ensure even lifting and lowering.

An upper limit bar prevents the vehicle from being lifted too high. This feature effectively protects taller vehicles from being damaged.

The electro-hydraulic design provides for low noise and effective work.

Each lifting column features a maintenance-free high pressure cylinder.

The patented double S-profile (Patent no. 5.009.287 USA) of the lifting columns provide for utmost stability at minimum space requirements. In addition, the contact surface area of the carriage slider bearings is considerably increased, which protects the column from premature wear.

For increased ergonomics and productivity, each lifting column on E-models have been equipped with their own control unit. Because of the workshop environment, the pushbuttons can also be pressed when wearing gloves.

The mechanical safety latch integrated on both columns locks the lift carriage in position in emergency situations and thus ensures maximum safety.

The two control units (E-models) are equipped with a 220 V GFI socket for connecting electrical equipment. Optionally, a compressed air connector can be provided.

The base frame free design eliminates the risk of trip hazards on the workshop floor and reduces installation cost.

The figure shows SPOA40E with optional accessories.

DETAILS

The supporting arms are automatically locked in position during the lifting operation. Once the lift has been completely lowered, this interlock is automatically released. The very narrow spacing between the locking positions and a manual unlocking function enhance the ease of use.

The powerful hydraulic unit is flange-mounted in the upper area of the lifting column. The motor is equipped with a temperature-operated switch as an overload protection. It is protected against outside influences and ensures more freedom of action and low noise in the work bay.

CONTROLLER VERSIONS

Manual control

- Conventional operation using two hands
- Manual lock release.
- Fine control lowering possible. This is important, e.g. in combination with straightening benches.
- Hydraulic design

Electrical control

- Single-hand operating unit on both lifting columns.
- Electrically controlled safety latches.
- Sensitive pushbuttons.
- Integrated 220 V connection, prepared for connecting compressed air.

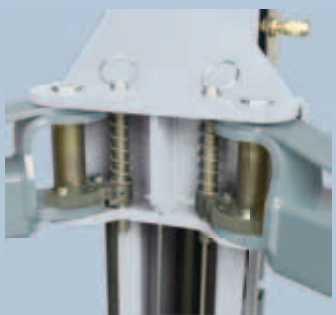

Model:	Asymmetric SPOA40M	Asymmetric SPOA40E	Symmetric SPO40M	Symmetric SPO40E
Capacity	4000 kg	4000 kg	4000 kg	4000 kg
A. Stroke	1959 mm	1959 mm	1979 mm	1979 mm
B. Overall height	3780 mm	3780 mm	3780 mm	3780 mm
EH1	3865 mm	3865 mm	3865 mm	3865 mm
EH2	4170 mm	4170 mm	4170 mm	4170 mm
EH4	-	-	4780 mm	4780 mm
C. Overall width (Outside of base plate)	3489 mm	3489 mm	3496 mm	3496 mm
D. Drive through clearance	2413 mm	2413 mm	2590 mm	2590 mm
E. Switchoff level	3455 mm	3455 mm	3455 mm	3455 mm
EH1	3760 mm	3760 mm	3760 mm	3760 mm
EH2	4065 mm	4065 mm	4065 mm	4065 mm
EH4	-	-	4675 mm	4675 mm
F. Support bracket length on the front min.	536 mm	536 mm	700 mm	700 mm
G. Support bracket length on the front max.	1105 mm	1105 mm	1500 mm	1500 mm
H. Support bracket length on the rear min.	837 mm	837 mm	700 mm	700 mm
I. Support bracket length on the rear max.	1475 mm	1475 mm	1500 mm	1500 mm
J. Rotary plate height min.	89 mm	89 mm	109 mm	109 mm
K. Rotary plate height max.	159 mm	159 mm	179 mm	179 mm
M. Column spacing, interior dimension	2699 mm	2699 mm	2908 mm	2908 mm
N. Cylinder height (at max. stroke)*	3785 mm	3785 mm	3785 mm	3785 mm
Motor performance	4 kW	4 kW	4 kW	4 kW
Electrical connection (3 phases)	230/400 V, 50 Hz	400 V, 50 Hz	230/400 V, 50 Hz	400 V, 50 Hz
Lifting time	29 sec.	29 sec.	29 sec.	29 sec.
Required ceiling height	3800 mm	3800 mm	3800 mm	3800 mm
EH1	3920 mm	3920 mm	3920 mm	3920 mm
EH2	4230 mm	4230 mm	4230 mm	4230 mm
EH4	-	-	4840 mm	4840 mm

* Cylinder height with standard models larger than overall height.

M Manual control
E Electrical control

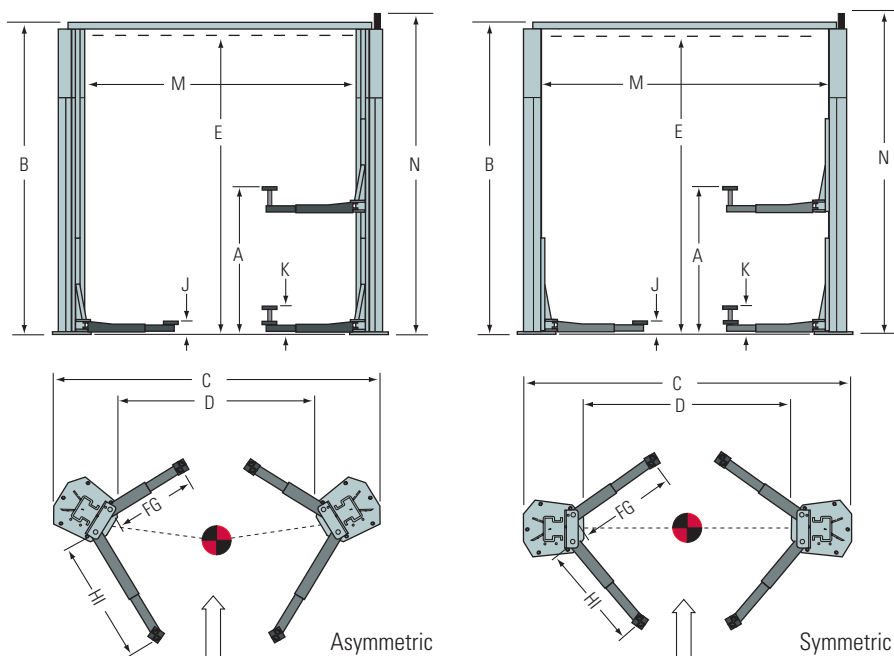

ACCESSORIES

Rotary adaptor extension kit for passenger cars (4 x 89 mm, 4 x 127 mm)



Rotary adaptor extension kit for delivery trucks/vans (4 x 200 mm)



Tool storage trays, magnetic



Vehicle security for rotary plate with 120 mm diameter



Support kit for delivery trucks/vans (4 x U-support)

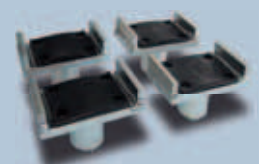

SPOA54, SPO65

ON ACCOUNT OF THEIR HIGH LOAD BEARING CAPACITY THE SPO54 AND THE NEW SPO65 ARE ESPECIALLY SUITABLE FOR LIGHT-DUTY COMMERCIAL VEHICLES – THE SPO65 ESPECIALLY FOR VEHICLES WITH A LONG WHEELBASE (E.G. MERCEDES-BENZ SPRINTER AND VOLKSWAGEN CRAFTER). THERE IS ONE MANUAL AND ONE ELECTRICAL CONTROLLER VERSION TO CHOOSE FROM.

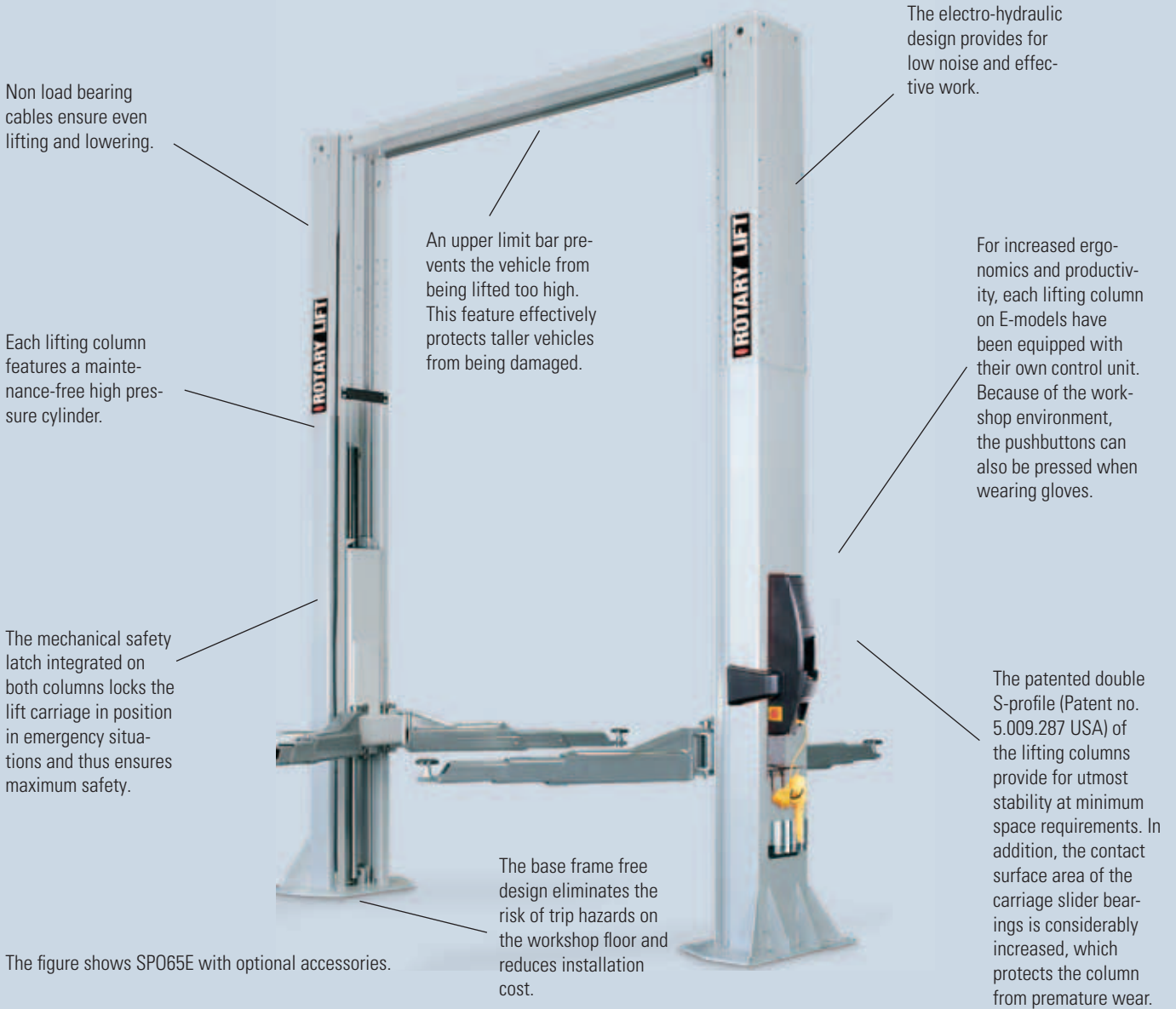

DETAILS

The lift carriage bearings are made of self-lubricating and absolutely maintenance-free Tivar® 1000 polyethylene. Two characteristics that help reduce operating expenses considerably.

The supporting arms are automatically locked in position during the lifting operation. Once the lift has been completely lowered, this interlock is automatically released. The very narrow spacing between the locking positions and a manual unlocking function enhance the ease of use.

CONTROLLER VERSIONS

Manual control

- Conventional operation using two hands
- Manual lock release.
- Fine control lowering possible. This is important, e.g. in combination with straightening benches.
- Hydraulic design

Electrical control

- Single-hand operating unit on both lifting columns.
- Electrically controlled safety latches (SPO65 pneumatically).
- Sensitive pushbuttons.
- Integrated 220 V connection, prepared for connecting compressed air.

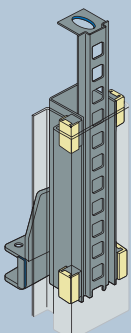

Model:	SP054M	SP054E	SP065E-LWB
Capacity	5000 kg	5000 kg	6500 kg
A. Stroke	1997 mm	1989 mm	2005 mm
B. Overall height	4170 mm	4170 mm	4546-5004 mm*
	EH1	4475 mm	4475 mm
	EH2	4780 mm	4780 mm
C. Overall width (Outside of base plate)	3496 mm	3496 mm	3937 mm
D. Drive through clearance	2613 mm	2613 mm	2687 mm
E. Switchoff level	4065 mm	4065 mm	4436-4894 mm*
	EH1	4360 mm	4360 mm
	EH2	4675 mm	4675 mm
F. Support bracket length on the front min.	700 mm	700 mm	935 mm
G. Support bracket length on the front max.	1500 mm	1500 mm	1901 mm
H. Support bracket length on the rear min.	700 mm	700 mm	935 mm
I. Support bracket length on the rear max.	1500 mm	1500 mm	1901 mm
J. Rotary plate height min.	129 mm	119 mm	115 mm
K. Rotary plate height max.	197 mm	189 mm	175 mm
M. Column spacing, interior dimension	2915 mm	2915 mm	3058 mm
Motor performance	3 kW	3 kW	3 kW
Electrical connection (3 phases)	230/400 V, 50 Hz	230/400 V, 50 Hz	230/400 V, 50 Hz
Lifting time	60 sec.	60 sec.	60 sec.
Required ceiling height	4230 mm	4230 mm	4700-5150 mm*
	EH1	4530 mm	-
	EH2	4840 mm	-

M Manual control
E Electrical control

* can be adjusted every 150 mm

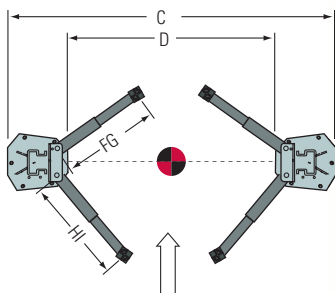
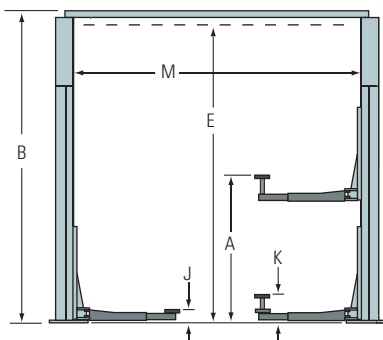

ACCESSORIES

Rotary adaptor extension kit for passenger cars (4 x 89 mm, 4 x 127 mm)



Rotary adaptor extension kit for delivery trucks/vans (4 x 200 mm)



Tool storage trays, magnetic



Vehicle security for rotary plate with 120 mm diameter



Support kit for delivery trucks/vans (4 x U-support)

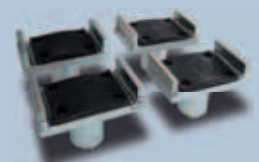

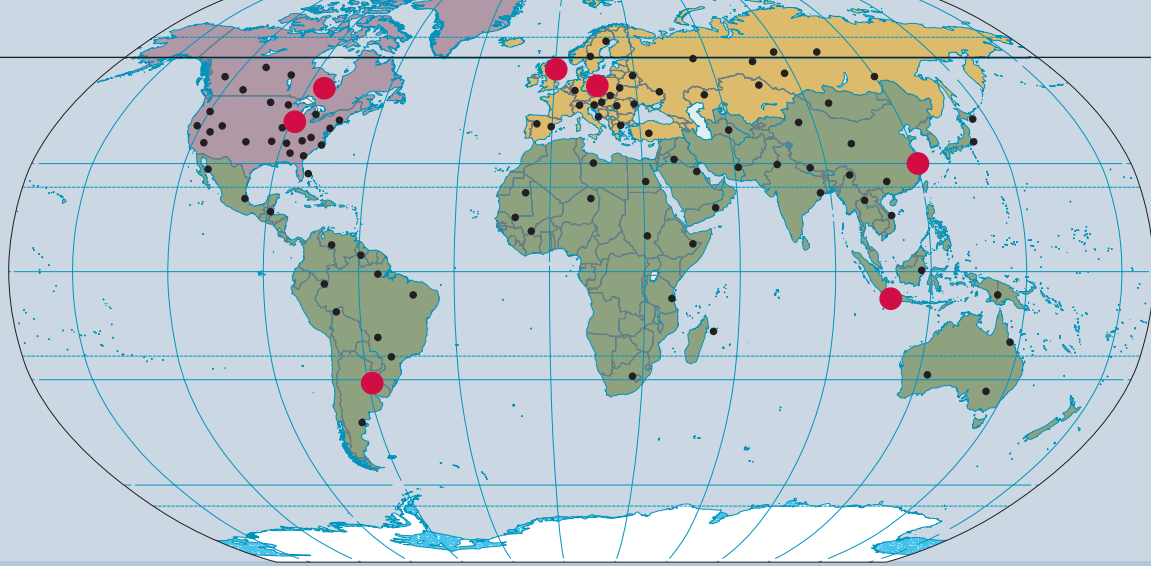

LOOK LOCAL - ACT GLOBAL

WE ACT WITH FOCUS ON OUR CUSTOMERS AND THEIR REQUIREMENTS. LOCAL SUBSIDIARIES WORLDWIDE PERMIT US TO DO SO, AND AT THE SAME TIME, OFFER A HIGH DEGREE OF PRODUCT FLEXIBILITY.

Rotary Lift's story of success started in 1924. Inspired by a barber chair rising in the air, company founder Peter Lunati developed the world's first vehicle lift. The lift could rotate. This design made it possible for vehicles to drive on and off the lift in forward gear. An important argument considering the frequent problem of reversing at that time. The patent for the lift was granted on September 1, 1925 and Rotary Lift – the company – was born.

Over 75 years later, Rotary Lift has grown to become the world leader in vehicle lift productivity. Apart from the headquarters in Madison, Indiana (USA) and the European Control Center in Bräunlingen, Germany, numerous global subsidiaries attend to the desires and requirements of our customers.

With this unique network, Rotary Lift has the opportunity of analyzing and recognizing market trends at an early stage and of applying that knowledge to generate global standards. Worldwide product releases of numerous vehicle manufacturers emphasize this approach.



Headquarter
Madison, IN USA

European Control Center
Bräunlingen, Germany

Rotatable
One of the first lifts of Rotary Lift



BlitzRotary GmbH
Hüfanger Straße 55
D-78199 Bräunlingen
A **DOVER** COMPANY

Fon +49.771.9233.0
Fax +49.771.9233.99
info@blitzrotary.com
www.blitzrotary.com

USA: +1.812.273.1622 (Headquarter)
Canada: +1.905.812.9920
United Kingdom: +44.178.747.7711
AustralAsia: +60.3.7660.0285

